

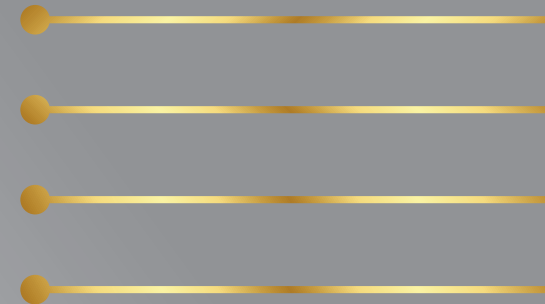

Makkah
For Air Outlets



FIRE DAMPERS (FD)

Fire Damper Curtain Type with Blades
Inside Air Stream
FDI

Product Description

Model FDI is approved for use in wall, floor and partitions with fire resistance ratings of hours or more. This model carries a 3 Hour UL fire damper label.. The UL 555 classifies dynamic rated fire dampers for use in HVAC systems that are automatically shut down in the event of fire.

-Folding blades fire dampers designed impede to stop the spread of fire throughout ventilation “duct” systems.

-Curtain blades fire dampers are suitable for installation in walls, floors, ceilings, doors and partitions.

Wide choice of sizes suitable for low, medium or high velocity application.

-Fire dampers are fitted with 72°C (165°F) fusible links [UL listed].



Model FDI meets the requirements for fire dampers established by Underwriters Laboratories standard 555 (Listing # R 27026)

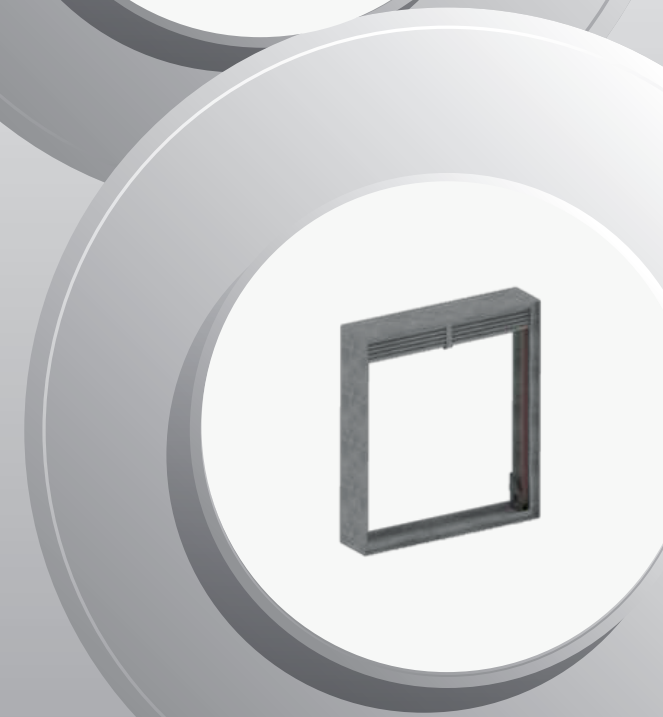

Fire Damper Parts

- 1. Stainless steel closure spring.
- 2. Locking ramp
- 3. Fusible link (72°C) UL listed]
- 4. Top blades are riveted to frame
- 5. Galvanized steel casing
- 6. Galvanized steel blades

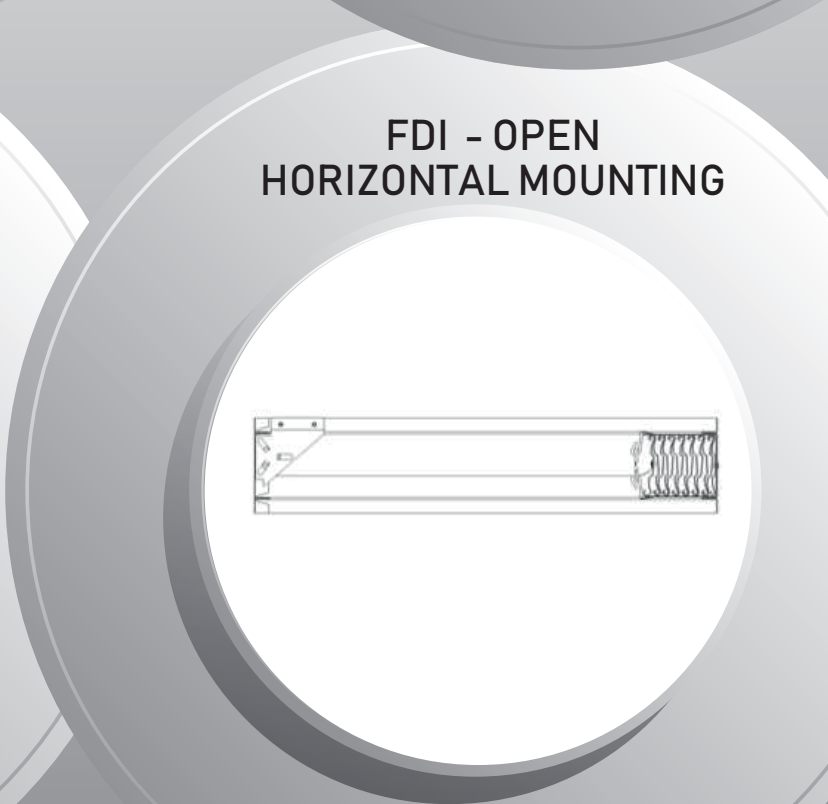
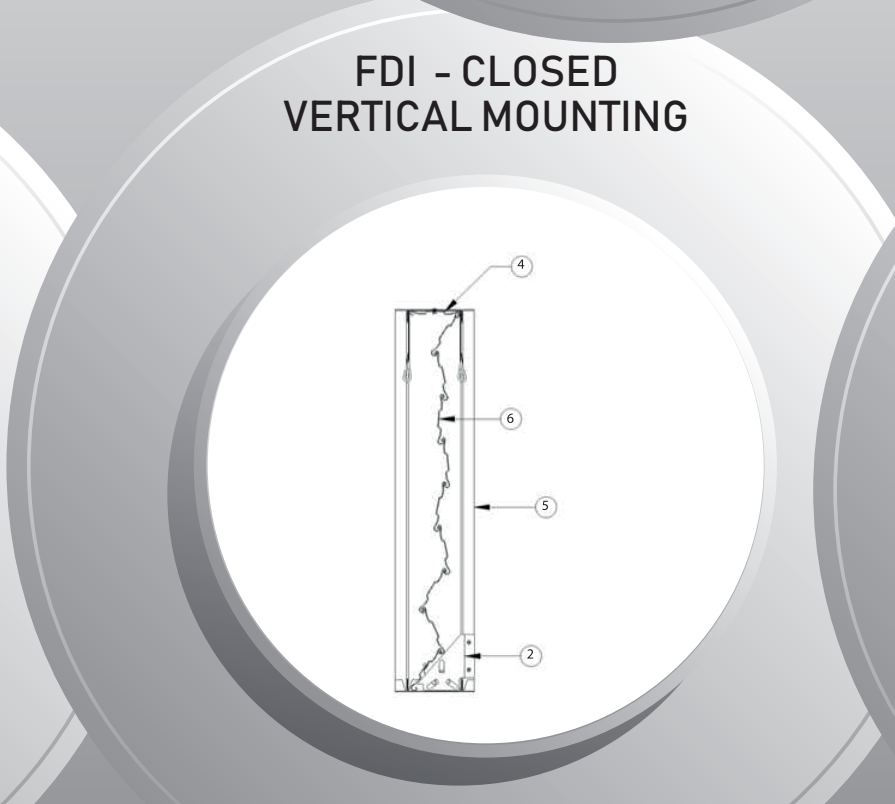
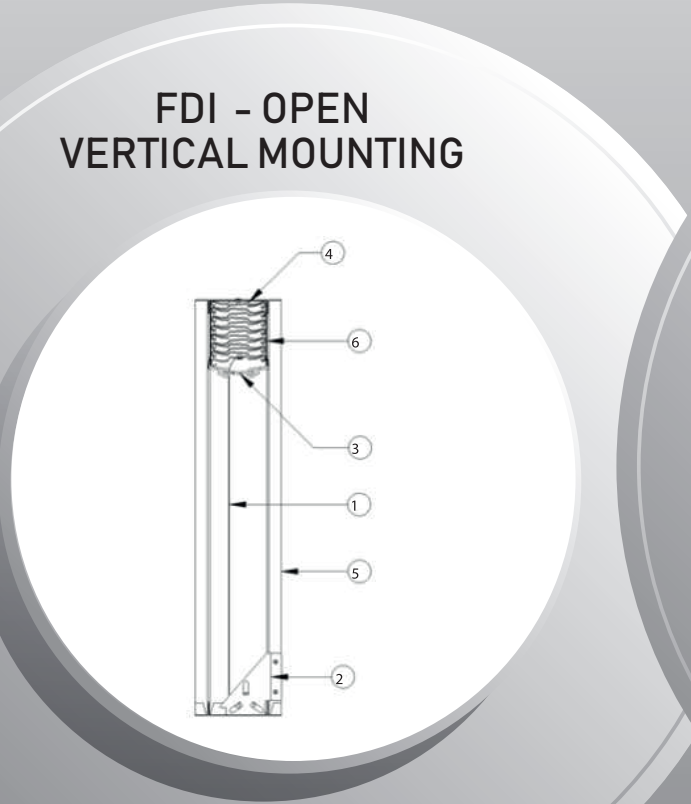
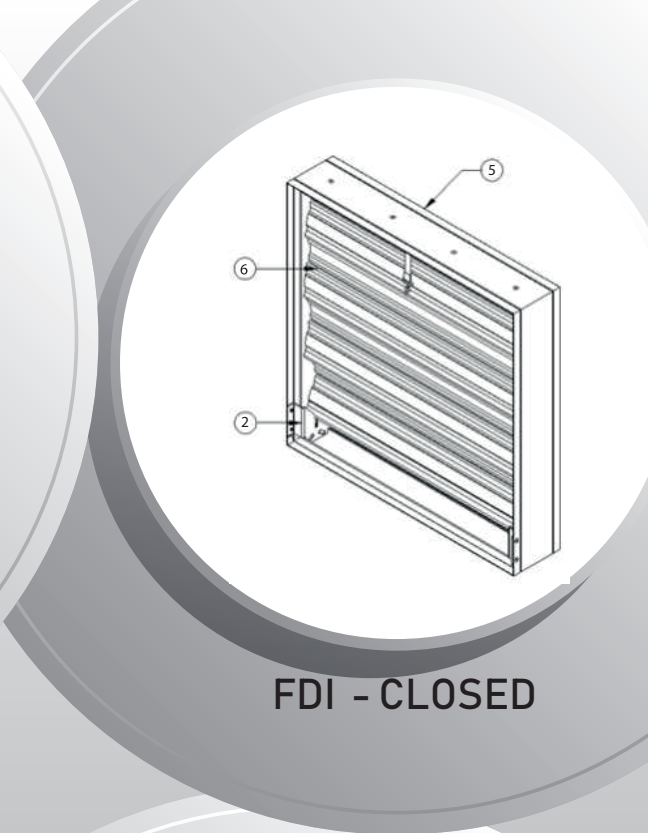
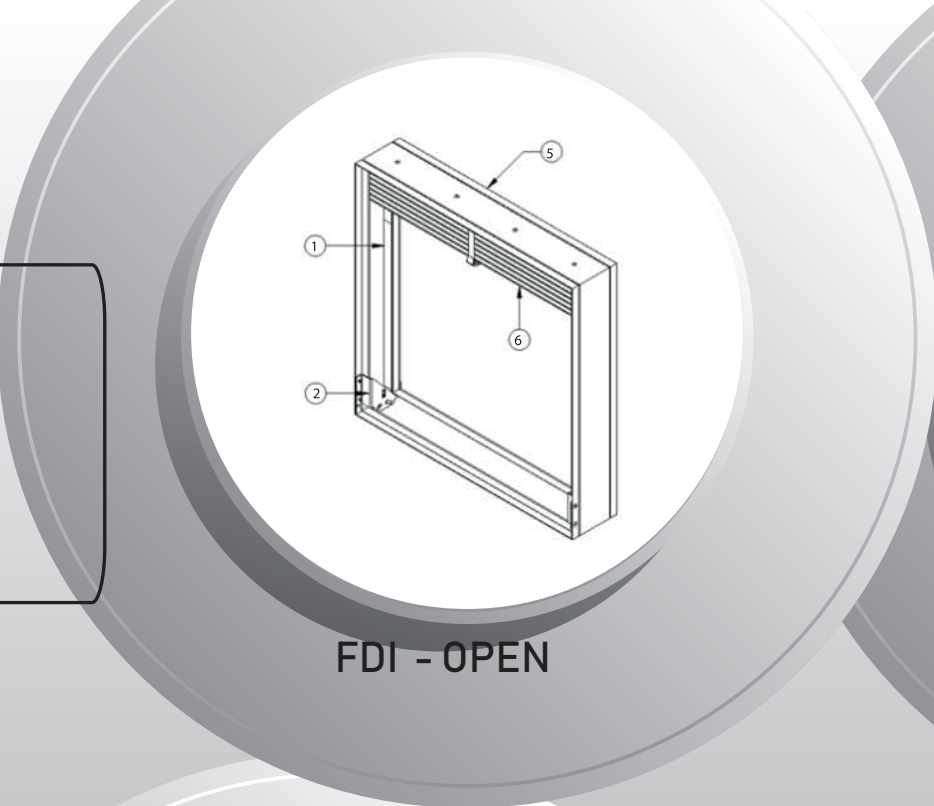

Dimensions

Standard Construction

Frame	Built of 20 gauge galvanized
Blade	20 gauge galvanized steel.
Finish	Mill galvanized.
Fusible link	72°c (165°F) UL listed.
Spring	Stainless steel closure springs.
Fire rating	3 hours
Minimum size	4'x4'
Maximum size	36'x36' as a single section.

Multiple section assembly with unlimited size, where each section operates independently. For detail of multiple sections consult Makkah Al Takyeef Factory

Isometric View

Dimensions H and W shall be furnished approximately

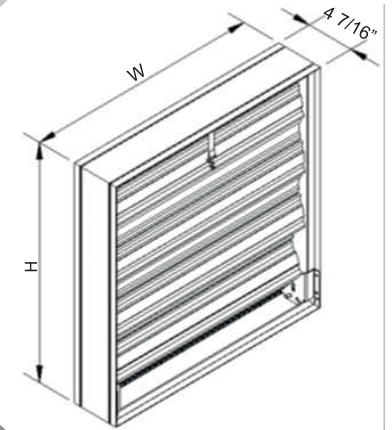

Sectional Side View

5mm undersize the nominal height and width of duct.

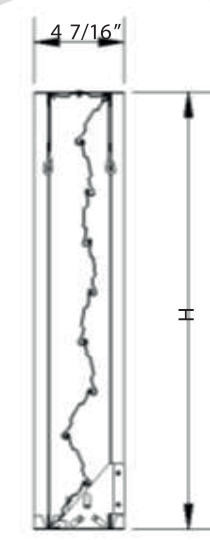

Fire Damper Curtain Type with Blades

Outside Air Stream

FDO

Product Description

- Folding blades fire dampers designed impede to stop the spread of fire throughout ventilation ' duct' systems.
- Curtain blades fire dampers are suitable for installation in walls, floors, ceilings, doors and partitions.
- Wide choice of sizes suitable for low, medium or high velocity application.
- Fire dampers are fitted with 72°C (165° F) fusible links [UL listed].

Standard Construction

Frame	Built of 20 gauge galvanized
Blade	20 gauge galvanized steel.
Finish	Mill galvanized.
Fusible link	72°c (165°F) UL listed.
Spring	Stainless steel closure springs.
Fire rating	3 hours
Minimum size	4'x4'
Maximum size	36'x36' as a single section.
	Multiple section assembly with unlimited size, where each section operates independently. For detail of multiple sections consult Makkah Al Takyeef Factory



Dimensions

1. Stainless steel closure spring.
2. Locking ramp
3. Fusible link (72°C) UL listed
4. Top blades are riveted to frame
5. Galvanized steel casing
6. Galvanized steel blades

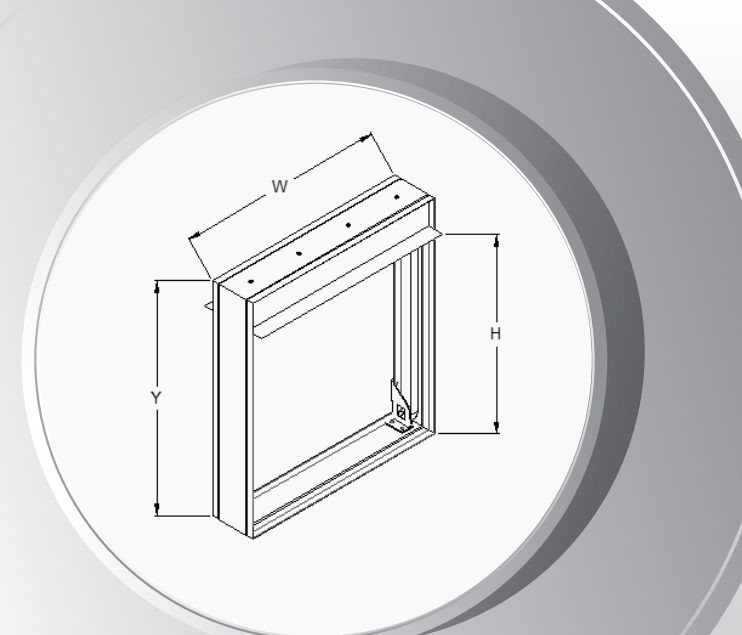

Standard sizes

H (inch)	Y (inch)	H (inch)	Y (inch)
4	5	23	25 3/8
5	6	24	26 3/8
6	7 1/8	25	27 1/2
7	8 1/8	26	28 1/2
8	9 1/4	27	29 1/2
9	10 1/4	28	30 5/8
10	11 1/2	29	31 5/8
11	12 1/2	30	32 3/4
12	13 3/8	31	33 3/4
13	14 5/8	32	35
14	15 1/2	33	36
15	16 3/4	34	37 1/8
16	17 3/4	35	38 1/8
17	18 7/8	36	39 1/4
18	19 7/8	37	40 1/4
19	21 1/8	38	41 3/8
20	22	39	42 3/8
21	23 1/4	40	43 5/8
22	24 1/8	41	44 5/8

Dimensions H and W shall be furnished approximately 5mm undersize the nominal height and width of duct.

HORIZONTAL MOUNTING

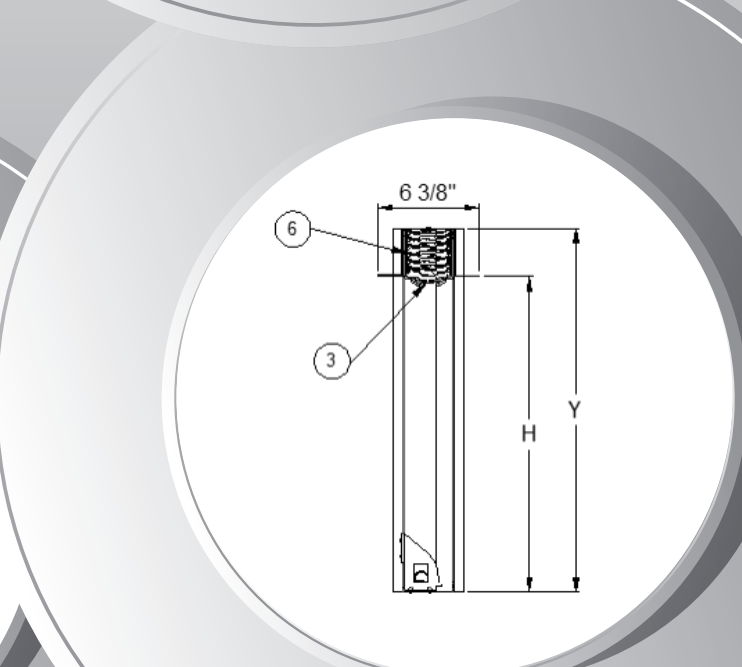
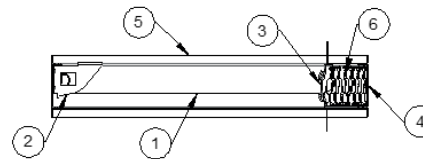

VERTICAL MOUNTING

Fire Damper Curtain Type Rectangular FDR

Product Description

- Folding blades fire dampers designed impede to stop the spread of fire throughout ventilation ' duct' systems.
- Curtain blades fire dampers are suitable for installation in walls, floors, ceilings, doors and partitions.
- Wide choice of sizes suitable for low, medium or high velocity application.
- Fire dampers are fitted with 72°C (165° F) fusible links [UL listed].

Standard Construction

Frame	Built of 20 gauge galvanized
Blade	20 gauge galvanized steel.
Finish	Mill galvanized.
Fusible link	72°c (165°F) UL listed.
Spring	Stainless steel closure springs.
Fire rating	3 hours
Minimum size	4'x4'
Maximum size	36'x36' as a single section.
	Multiple section assembly with unlimited size, where each section operates independently. For detail of multiple sections consult Makkah Al Takyeef Factory



Dimensions

1. Stainless steel closure spring.
2. Locking ramp
3. Fusible link (72°C) UL listed
4. Top blades are riveted to frame
5. Galvanized steel casing
6. Galvanized steel blades

Standard sizes

H (inch)	Y (inch)	H (inch)	Y (inch)
4	6	23	26 3/4
5	7 1/4	24	27 7/8
6	8 1/4	25	28 7/8
7	9 3/8	26	30 1/8
8	10 3/8	27	31 1/8
9	11 3/8	28	32 1/4
10	12 5/8	29	33 1/4
11	13 5/8	30	34 1/4
12	14 3/4	31	35 1/2
13	15 3/4	32	36 1/2
14	17	33	37 5/8
15	18	34	38 5/8
16	19 1/8	35	39 7/8
17	20 1/8	36	40 7/8
18	21 3/8	37	42
19	22 3/8	38	43
20	23 1/2	39	44 1/4
21	24 1/2	40	45 1/4
22	25 3/4	41	46 3/8

$$X = W + 2''$$

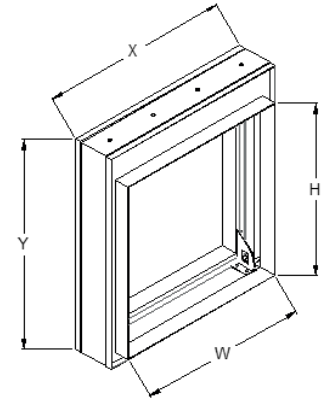

Dimensions H and W shall be furnished approximately 5mm undersize the nominal height and width of duct.

HORIZONTAL MOUNTING

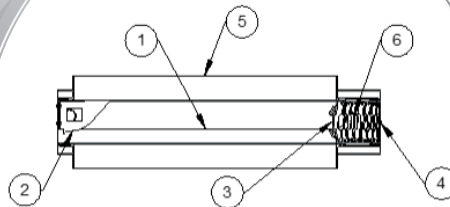

VERTICAL MOUNTING

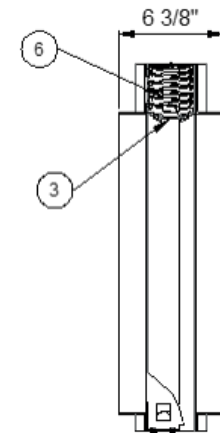

Fire Damper Curtain Type With Round Duct Connection

FDSR

Product Description

- Folding blades fire dampers designed impede to stop the spread of fire throughout ventilation ' duct' systems.
- Curtain blades fire dampers are suitable for installation in walls, floors, ceilings, doors and partitions.
- Wide choice of sizes suitable for low, medium or high velocity application.
- Fire dampers are fitted with 72°C (165° F) fusible links [UL listed].
- Round duct connection provides 100% free area.

Standard Construction

Frame	Built of 20 gauge galvanized
Blade	20 gauge galvanized steel.
Finish	Mill galvanized.
Fusible link	72°c (165°F) UL listed.
Spring	Stainless steel closure springs.
Fire rating	3 hours
Minimum size	6"
Maximum size	24" as a single section.
	Multiple section assembly with unlimited size, where each section operates independently. For detail of multiple sections consult Makkah Al Takyeef Factory



Dimensions

- 1. Stainless steel closure spring.
- 2. Locking ramp
- 3. Fusible link (72°C) UL listed
- 4. Top blades are riveted to frame
- 5. Galvanized steel casing
- 6. Galvanized steel blades

Standard sizes

Ø (inch)	Y (inch)	Ø (inch)	Y (inch)
4	6	23	26 3/4
5	7 1/4	24	27 7/8
6	8 1/4	25	28 7/8
7	9 3/8	26	30 1/8
8	10 3/8	27	31 1/8
9	11 3/8	28	32 1/4
10	12 5/8	29	33 1/4
11	13 5/8	30	34 1/4
12	14 3/4	31	35 1/2
13	15 3/4	32	36 1/2
14	17	33	37 5/8
15	18	34	38 5/8
16	19 1/8	35	39 7/8
17	20 1/8	36	40 7/8
18	21 3/8	37	42
19	22 3/8	38	43
20	23 1/2	39	44 1/4
21	24 1/2	40	45 1/4
22	25 3/4	41	46 3/8

$X = \text{Ø} + 2''$

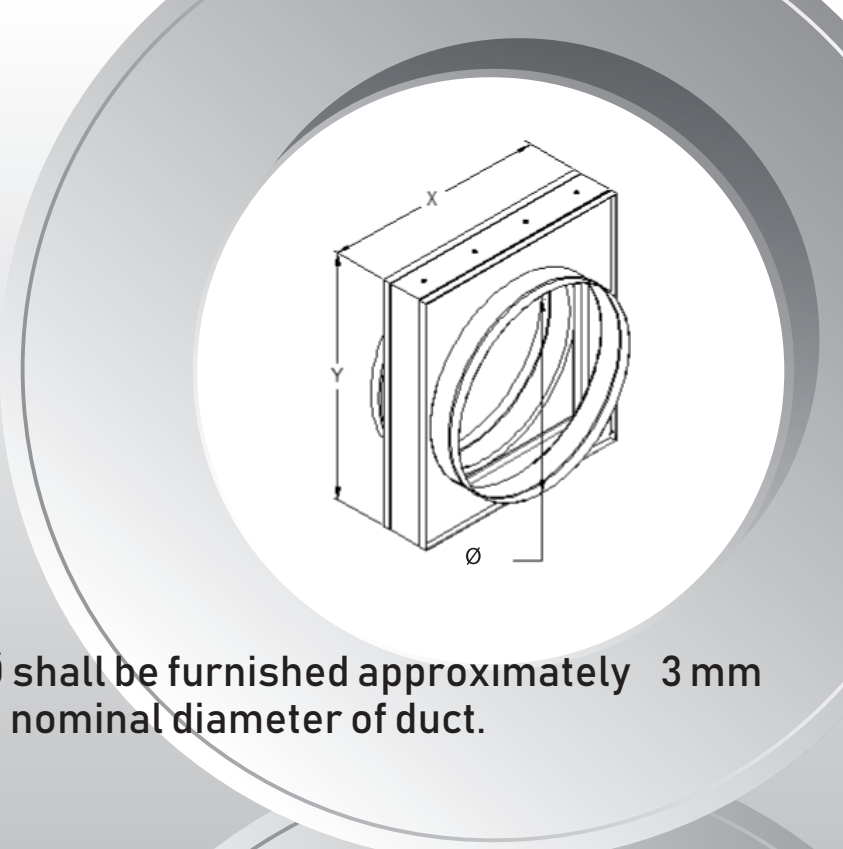

Dimensions Ø shall be furnished approximately 3 mm undersize the nominal diameter of duct.

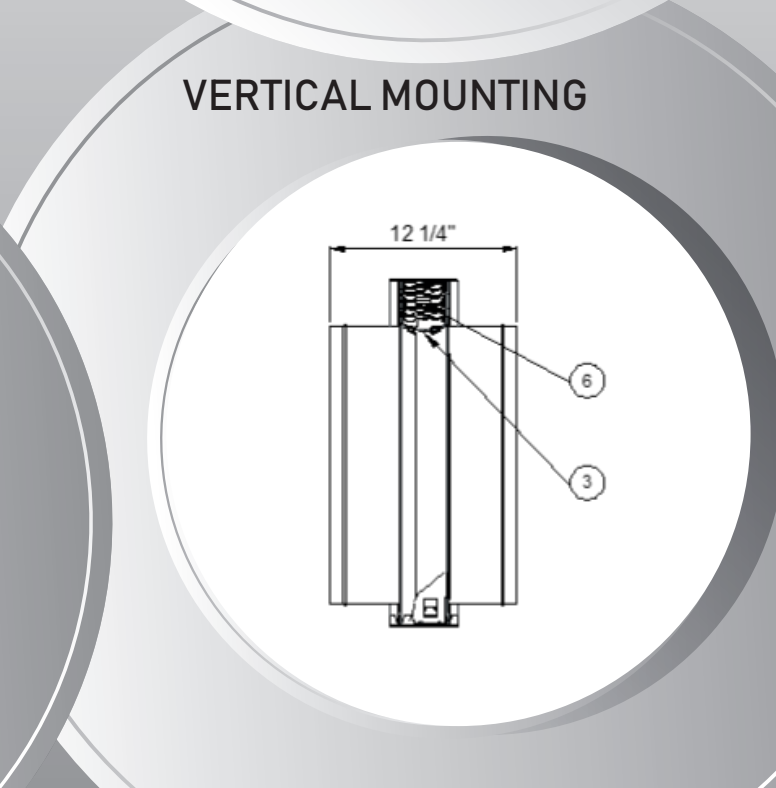
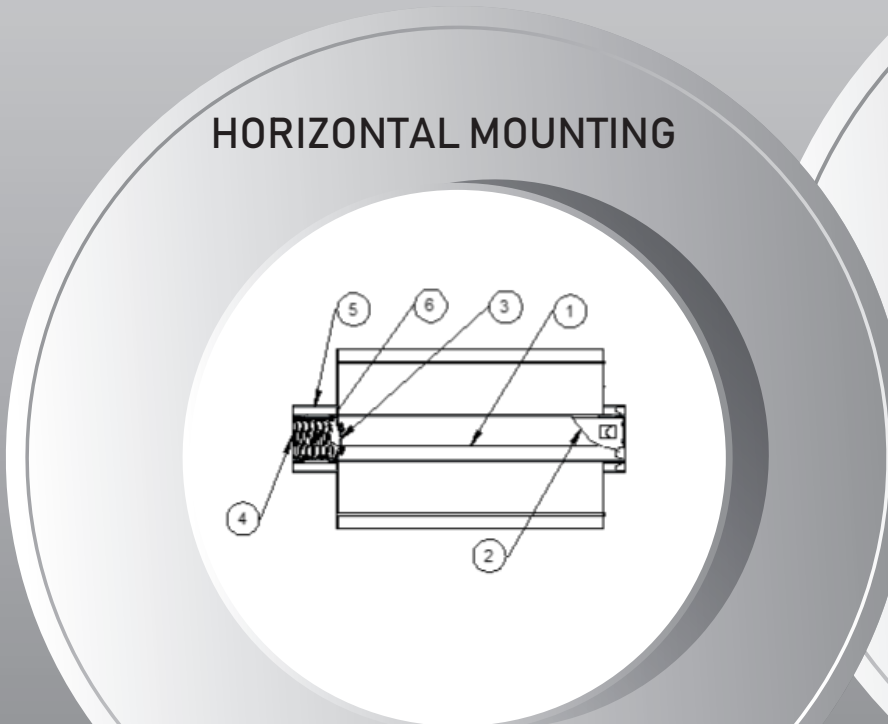

Fire Damper Curtain Type with Oval Duct Connection

FDSO

Product Description

- Folding blades fire dampers designed impede to stop the spread of fire throughout ventilation ' duct' systems.
- Curtain blades fire dampers are suitable for installation in walls, floors, ceilings, doors and partitions.
- Wide choice of sizes suitable for low, medium or high velocity application.
- Fire dampers are fitted with 72°C (165° F) fusible links [UL listed].
- Oval duct connection provides 100% free area.

Standard Construction

Frame	Built of 20 gauge galvanized
Blade	20 gauge galvanized steel.
Finish	Mill galvanized.
Fusible link	72°c (165°F) UL listed.
Spring	Stainless steel closure springs.
Fire rating	3 hours
Minimum size	4'x4'
Maximum size	36'x36' as a single section.
	Multiple section assembly with unlimited size, where each section operates independently. For detail of multiple sections consult Makkah Al Takyeeef Factory



Dimensions

1. Stainless steel closure spring.
2. Locking ramp
3. Fusible link (72°C) UL listed
4. Top blades are riveted to frame
5. Galvanized steel casing
6. Galvanized steel blades

Standard sizes

H (inch)	Y (inch)	H (inch)	Y (inch)
4	6	23	26 3/4
5	7 1/4	24	27 7/8
6	8 1/4	25	28 7/8
7	9 3/8	26	30 1/8
8	10 3/8	27	31 1/8
9	11 3/8	28	32 1/4
10	12 5/8	29	33 1/4
11	13 5/8	30	34 1/4
12	14 3/4	31	35 1/2
13	15 3/4	32	36 1/2
14	17	33	37 5/8
15	18	34	38 5/8
16	19 1/8	35	39 7/8
17	20 1/8	36	40 7/8
18	21 3/8	37	42
19	22 3/8	38	43
20	23 1/2	39	44 1/4
21	24 1/2	40	45 1/4
22	25 3/4	41	46 3/8

$$X = W + 2''$$

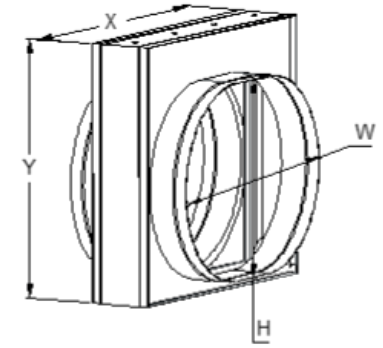

Dimensions H and W shall be furnished approximately 3 mm undersize the nominal height and width of duct.

HORIZONTAL MOUNTING

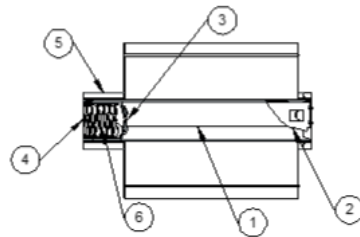

VERTICAL MOUNTING

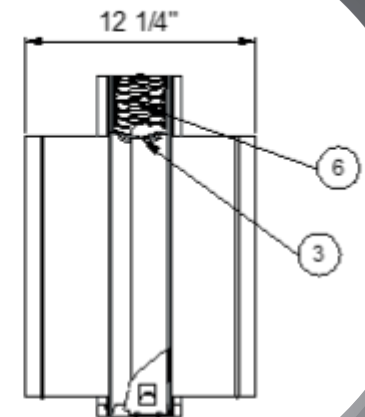

Fire Damper Blade Type FDB

Product Description

- Blade type fire damper is made of single or multi - blades
- Frame of damper flanged type or hat - shape of galvanized steel construction
- Blades are single skin, 3 - V and inter locking galvanized steel
- Optionally includes rectangular, square, circular or flat oval connections.
- The blades are mounted on self oiling bronze bushings.
- Fire dampers are fitted with 72° c (165° F) fusible links [UL listed].
- Fire Damper are tested to stand 3 - hours.

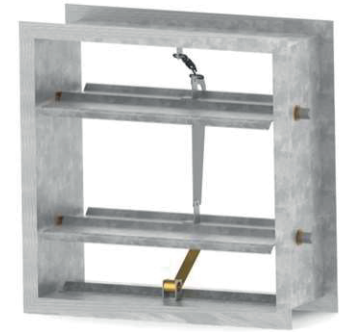

Standard Construction

Frame	: Flanged built of 6" 1"×16gauge galvanized steel. Or Hat - Shape built of 5"×7/8"×16gauge galvanized steel.
Blade	3 - V, built of 16 gauge galvanized steel.
Finish	: mill galvanized.
Fusible link	72°c (165°F) UL listed or Electronic fusible link 72°c (165°F). Other temperatures available on request.
Operation	: Stainless steel closure springs Or Spring - Return Electric Actuators.
Fire rating	3 hours
Minimum size	4" x 4"
Maximum size	36" x 36" as a single section. Multiple section assembly with unlimited size, where each section operates independently. For detail of multiple sections consult Makkah Al Takyeef Factory

1. Stainless steel closure spring.
2. Fusible link (72°C)
3. Galvanized steel frame
4. Galvanized steel blades
5. Catch device
6. Landing angle
7. Electric actuator

8. Electronic fusible link (72°C)
9. Linkage (Side of Face linkage)

Fire Damper with Closure Spring and Fusible Link (Mechanical)

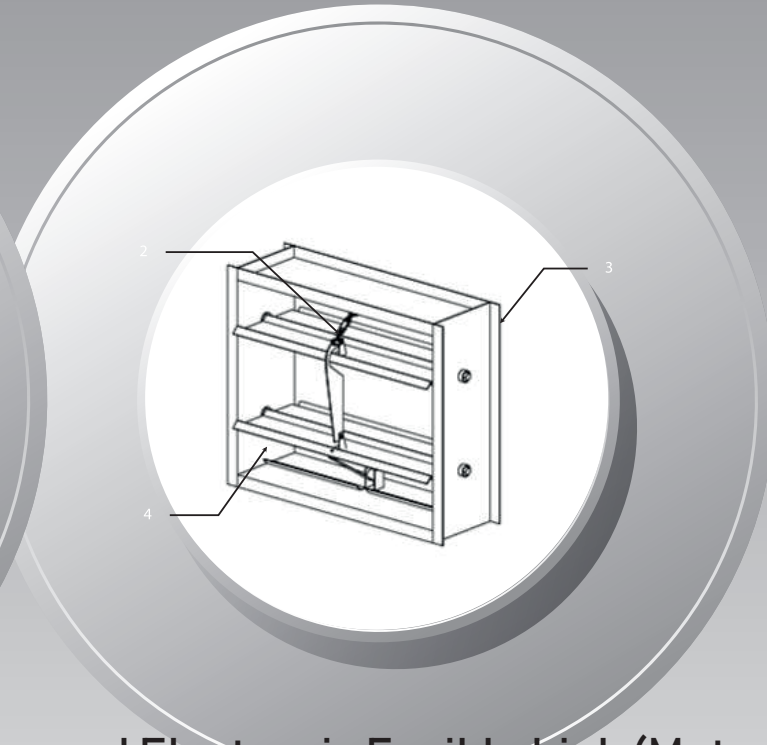
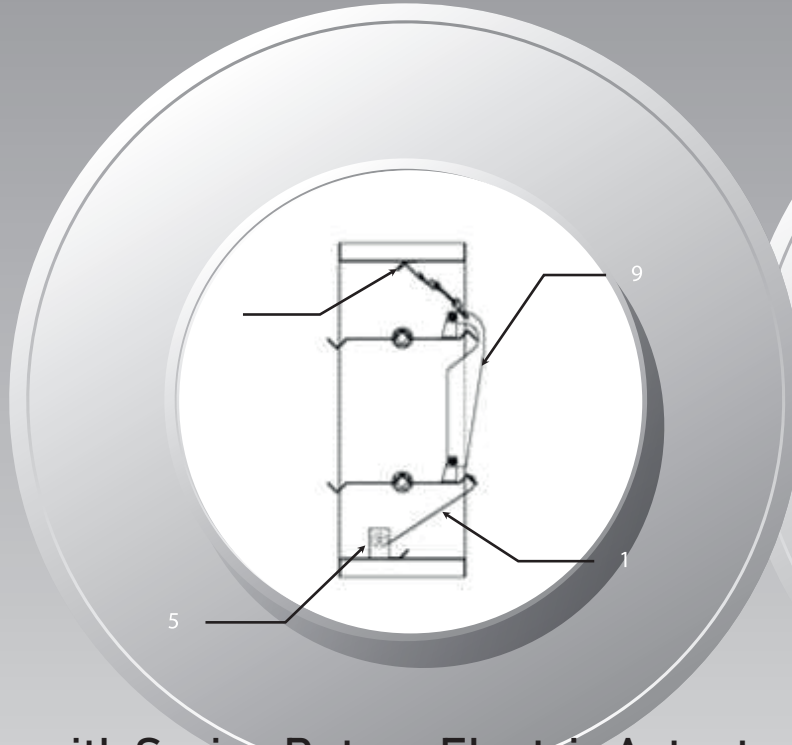

Fire Damper with Spring Return Electric Actuator and Electronic Fusible Link (Motorized)

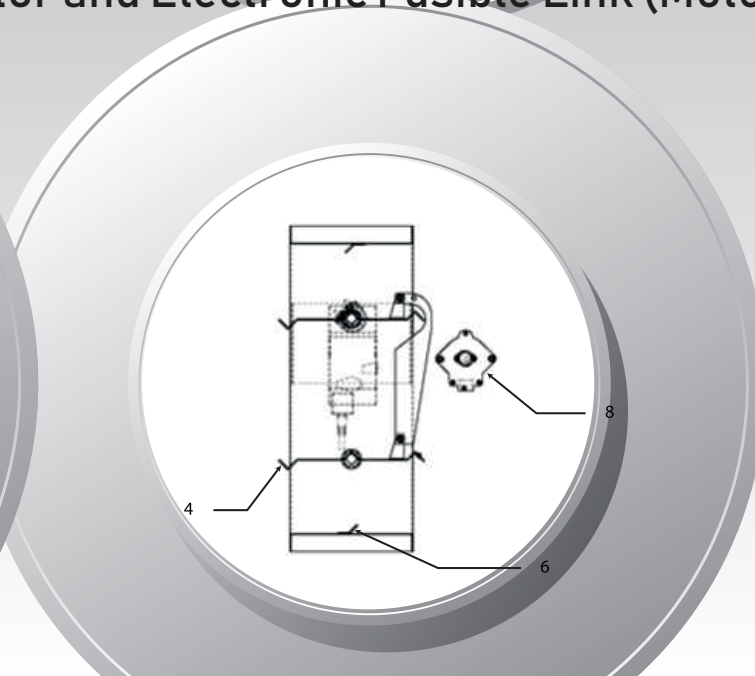
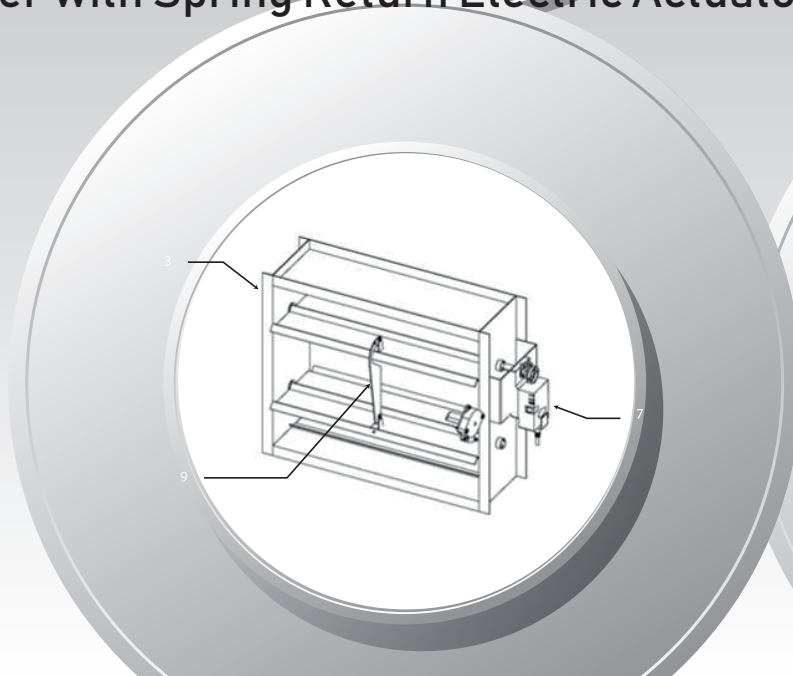

Fire Damper with Mounting Plate for Slip- In installation (applicable for both mechanical and motorized)

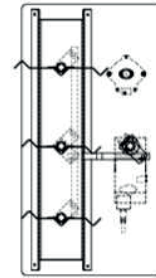
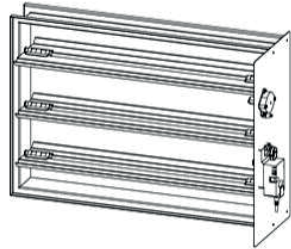

Fire Damper with Sleeve for wall installation (applicable for both mechanical and motorized)

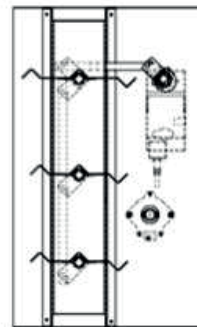
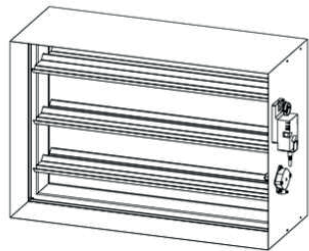

Dimensions For Flanged construction

W = Duct Width
H = Duct Height

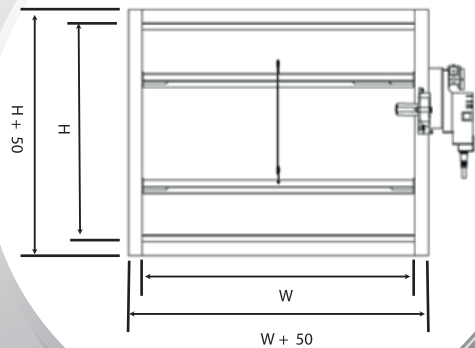
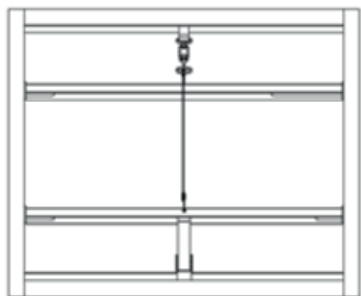

For Slip - In or Sleeve construction

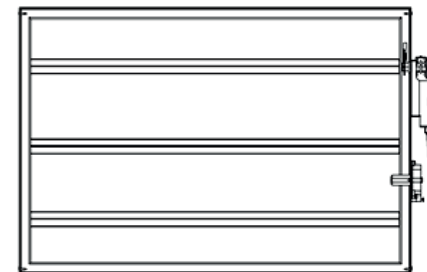

A = Duct Width (W) - 5mm
B = Duct Height (H) - 5mm

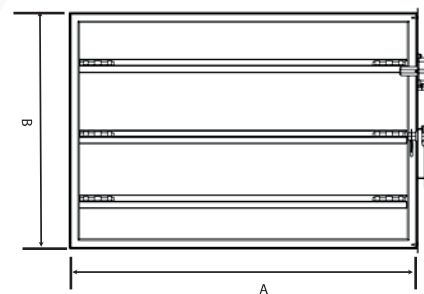

Multi Sections

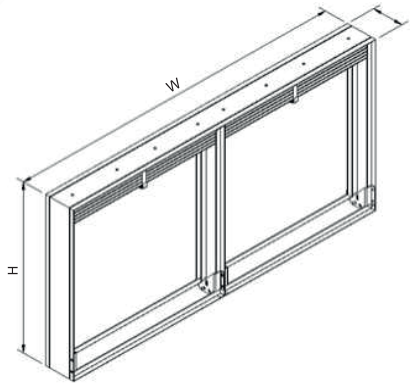

MODEL - FDI

MODEL - FDO

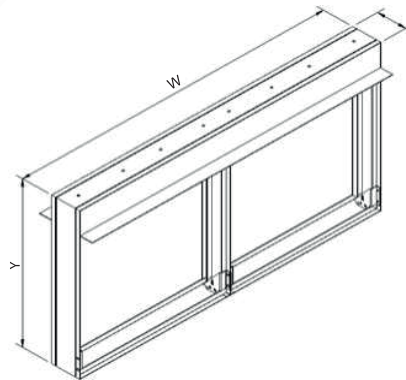

MODEL - FDSO

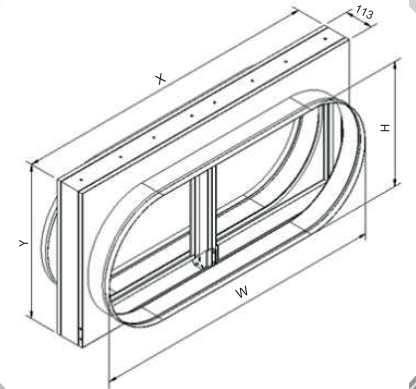

MODEL - FDSR

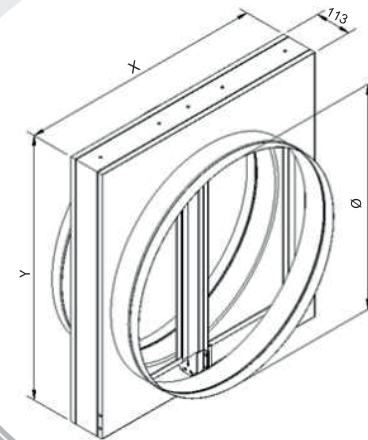

General Installation Notes

-These instructions apply to 3 hour rated fire dampers (blades must be horizontal) models FDI, mounted in concrete masonry, walls (Vertical) and concrete floors (Horizontal).

-Fire dampers are manufactured and labeled for either vertical or horizontal installation. Fire dampers are manufactured and labeled for either vertical or horizontal installation the locking ramp shall be always on top and lead blade pointing down.

FIRE DAMPER SLEEVE:

-All Fire Dampers should be installed in a Steel Sleeve with inside dimensions similar to Fire Damper outside Dimensions. The recommended minimum Sleeve thickness shall not be less than the duct thickness and shall as per Table 1 below.

-Fire Damper sleeve shall be fixed to the fire damper by a row of spot welds, rivets or #10 sheet metal self drilling screws at maximum distance of 50 mm (2 inch) from the edges and at spaced middle distances of maximum 150 mm (6 inch) center to center, as per Figure 1 below.

-The fire damper sleeve shall extend by maximum 150 mm (6 inch) from the wall of floor opening in both sides. In case there is an access door incorporated with the sleeve, it is allowed to extend by maximum 400 mm (16 inch) from the access door side. See Figures 2 and 3.

Sleeve Thickness			Duct Dimension		Type of Duct to Sleeve Connection Permitted
mm	inch	Gauge	mm	inch	
2.00 - 3.50	0.075 - 0.138	14 - 10	All Dimensions		Rigid or Breakaway
1.50	0.060	16	91 max. height 610 max. width 610 max. diameter	36 max. height 24 max. width 24 max. diameter	Rigid or Breakaway
1.50	0.060	16	All duct sizes		Breakaway only
1.20	0.048	18	2159 and over	85 and over	
0.90	0.036	20	1397 - 2134	55 - 84	
0.76	0.030	22	787 - 1372	31 - 54	
0.60	0.024	24	330 - 762	13 - 30	
0.46	0.018	26	305 and under	12 and under	

Table 1 (Minimum Sleeve Thickness)

FDI - Installation

FIGURE 1: Attaching Sleeve to Fire Damper

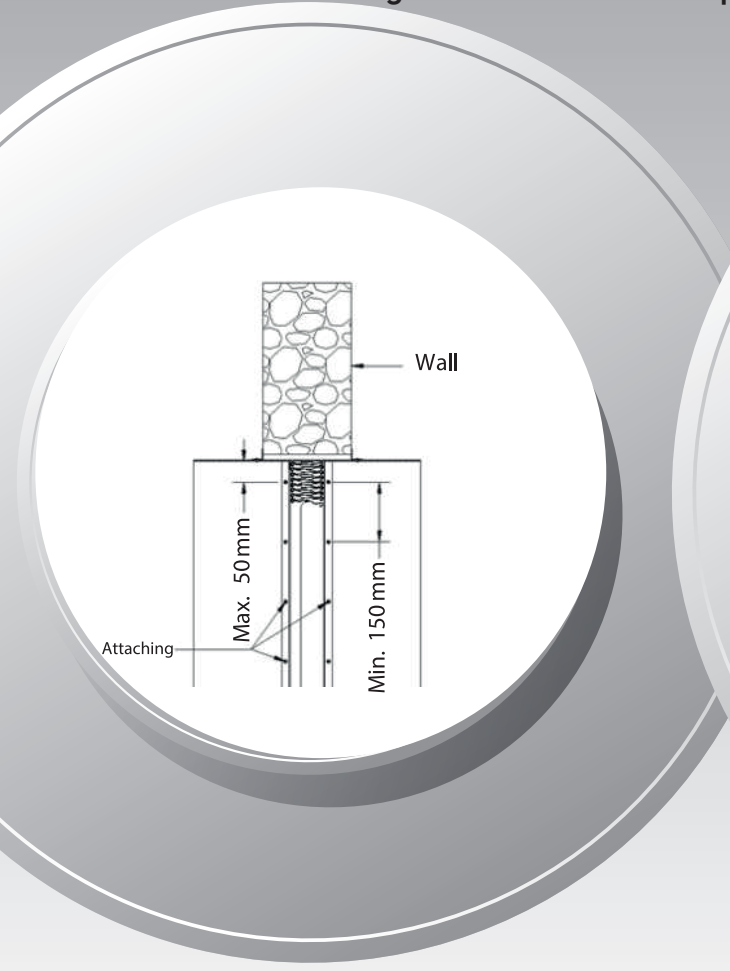

FIGURE 2: Vertical Installation

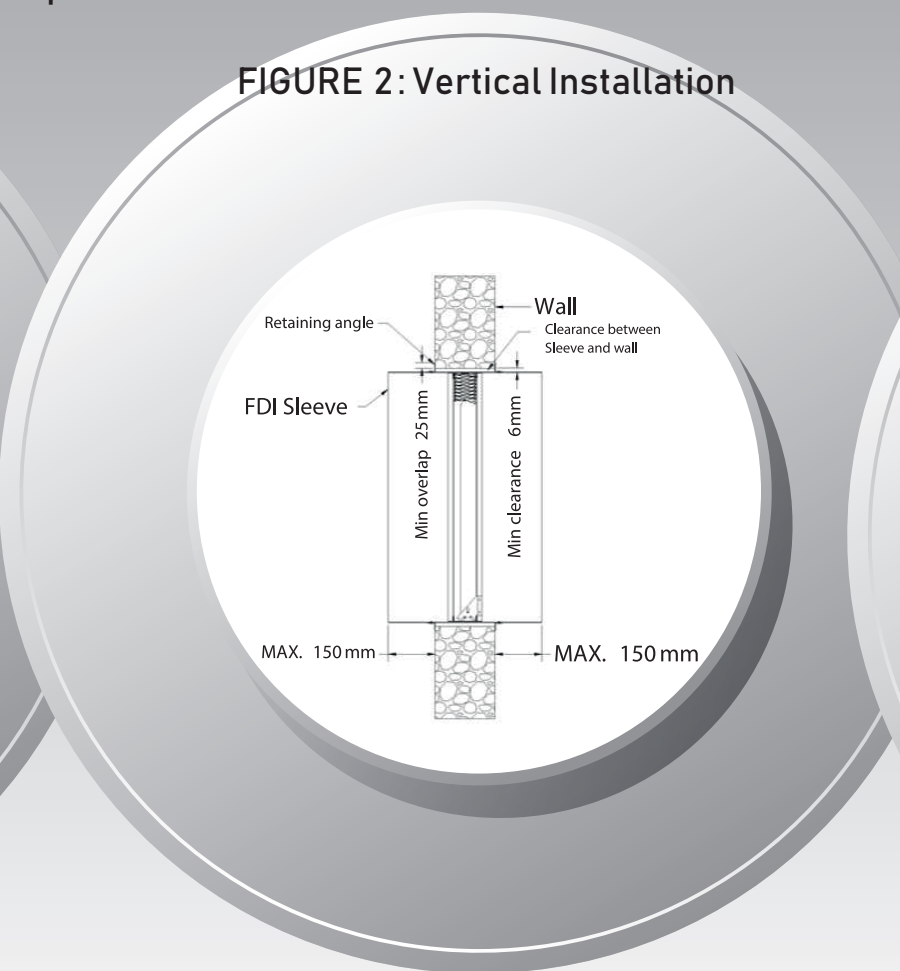
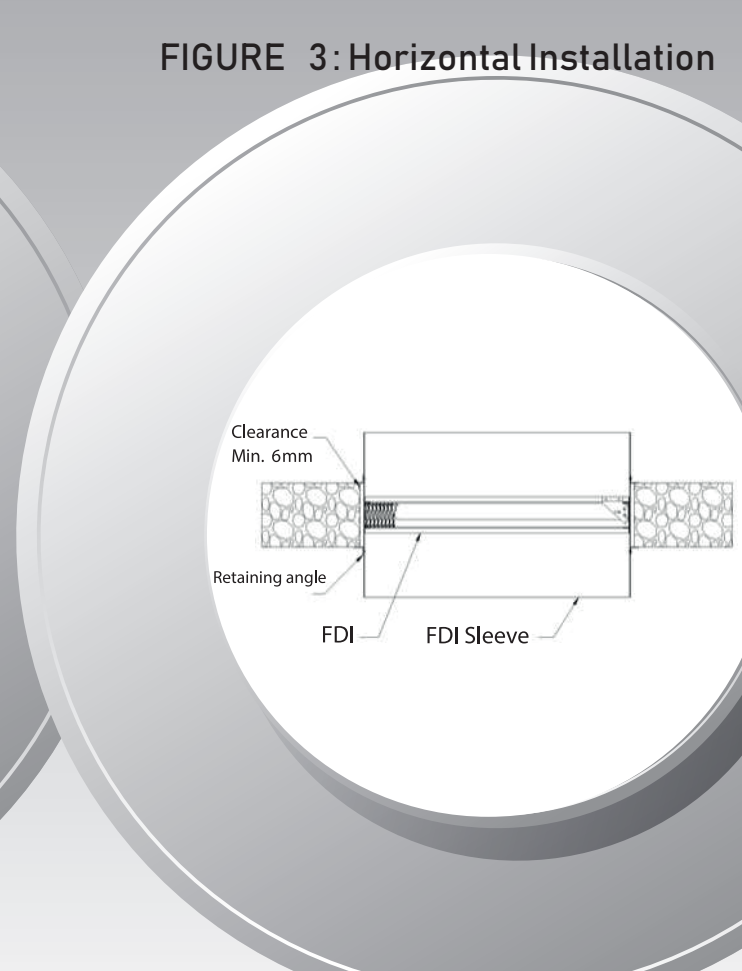

FIGURE 3: Horizontal Installation



CLEARANCES REQUIRED BETWEEN FIRE DAMPER SLEEVES AND WALL/FLOOR OPENINGS:

- Clearance between Fire Damper Sleeve and wall shall be minimum 10 mm per 1 meter (1/8inch per 1 foot) damper height and 10 mm per 1 meter (1/8inch per 1 foot) damper width but not less than 6 mm (1/4 inch) and not more than 50 mm (2 inch) in either directions. See Figures 2 and 3.
- These clearances are required to allow the expansion of fire damper and sleeve to fire elevated high temperature.

ATTACHING FIRE DAMPER SLEEVE TO WALL/FLOOR OPENINGS:

- Securing fire damper and sleeve to wall or floor opening shall be via retaining angles on each side of the wall and floor. Retaining angles shall be minimum 32 mm × 32 mm (1 inch). The thickness of retaining angles shall be of minimum 1.5 mm (0.060 inch or Gauge 16). Please refer to Figure 4
- The retaining angle should be fixed to the fire damper sleeve by a row of spot welds, rivets or #10 sheet metal self drilling screws at maximum distance of 50 mm (2 inch) from the edges and at spaced middle distances of maximum 150 mm (6 inch) center to center. The retaining angle should not be fastened to

FIGURE 4 Installing Sleeve to Wall/Floor

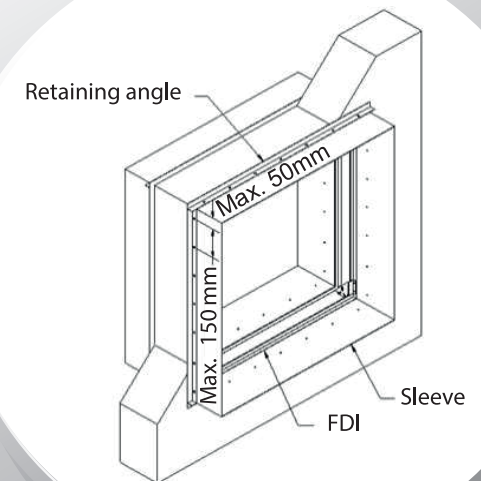

CONNECTING DUCTS TO FIRE DAMPER SLEEVE:

-Any duct connection other than shown on Figure 5 (Breakaway Connections) are considered as rigid connections.

-Breakaway connections shall be fixed to the sleeve by 2 pieces of #10 sheet metal self drilling screw on each side and on the bottom located in the center of the slip pocket and penetrating both sides of the slip pocket.

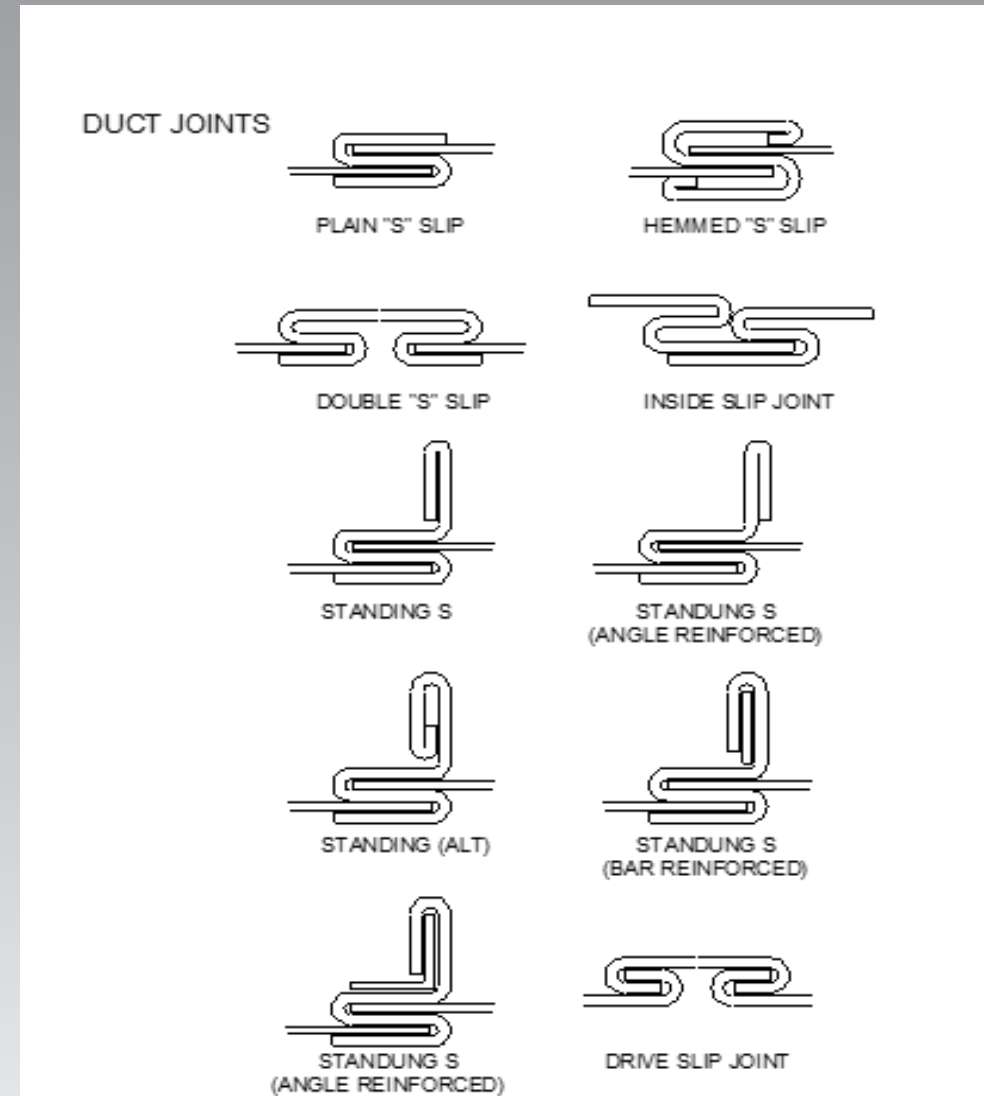

FIGURE 5: Breakaway Duct Connecting Joints